

LOOKING FOR INVISIBLE STORM WINDOWS?



Rawson House (1850), Cincinnati, Ohio



Faneuil Hall, (1742), Boston, Massachusetts



Historic Fourth Street, Cincinnati, Ohio



Executive Center East, Evansville, Indiana



Monticello
Charlottesville, VA



VA Tech Higher Learning Center
Roanoke, VA



Allied Window Facility
Cincinnati, Ohio

HERE THEY ARE!

Remarkable One-Of-A-Kind Storm Windows For Historic Properties, Commercial Buildings, Renovation Projects

Nowhere else in the country can you find these unique storm windows! They're custom-designed, engineered and crafted so that they seem to actually disappear in the opening. We achieve the invisible storm windows by using:

- Custom colors and finishes
- Special shapes
- Custom designs
- Heavy extruded frames
- Engineered installations

What's more, our storm windows have been approved for use on historic renovation projects certified by the Department of the Interior (National Park Services).

External Installation

Historic One Lite (HOL)

Internal Installation

Allied One Lite (AOL)

Magnetic One Lite (MOL)

Slide-A-Way (SAW)



Naturally, the traditional benefits of storm windows are also yours:

- **Energy Savings.** Energy loss through the window opening is reduced by almost 50%. Storm windows can be as energy-efficient as new windows — but at a fraction of the cost.
- **Comfort.** Drafts and uneven heating or cooling problems are eliminated.
- **Condensation.** Existing condensation problems are virtually eliminated.
- **Sound.** Outside noise is dramatically reduced.
- **Maintenance.** The life of the paint on the windows is prolonged; putty and plaster repairs are reduced.
- **Protection.** Special glazing protects existing windows from vandalism and provides additional security.

THE WINDOW PROFESSIONALS

SPECIFICATIONS AND DRAWINGS

Our Window Professionals work with owners, architects, building managers, engineers or other contractors to determine the customer's needs. Our goal is the optimum balance of performance, appearance and cost. Customer orientation to specifications, drawings and cost alternatives leads to informed decisions.

OFFICE BUILDINGS

Window performance, energy costs, maintenance, code requirements and tenant satisfaction are all critical factors in evaluating storm window systems. The installation of storm windows is an investment that quickly pays for itself, and helps your building appreciate in value and desirability.

INDUSTRIAL PLANTS

Most industrial storm window situations require a custom approach. Cost, energy savings and low maintenance are always key factors. We engineer alternative approaches utilizing the complete range of window products that we manufacture. These include storm windows, screens and guards.

QUALITY ASSURED

Since 1950, the name Allied Window, Inc. has been synonymous with superior craftsmanship and the finest quality materials available. That is why we can offer a **five-year warranty** on our manufactured products ... and a one-year warranty on our installations. You expect new windows to last for decades. So do we.

SCHOOLS, HOSPITALS, CHURCHES

By definition, institutions involve *people* ... and their needs are usually paramount in determining storm window requirements. Competent, professional help in reaching the right solution is our forte, as is *our* concern for *your* people.

RESIDENCES, APARTMENTS

Whether you own a castle or a cottage ... whether you own apartment buildings or manage them ... you need window professionals in whom you can place your trust—confident of receiving quality products with lasting value.

MAGNETIC ONE LITE "MOL"

Standard Design

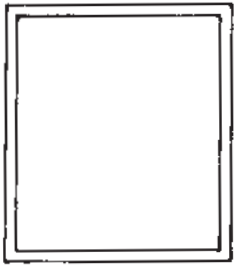

Lift-out Panel

The Magnetic One Lite (MOL) has been designed specifically for internal installation on commercial, industrial and residential buildings.

- Ideal secondary glazing for fixed windows and all styles of prime windows where ventilation is not a major factor. *Virtually invisible.*
- Tightest seal storm window design available.
- Frames and corners are heavy aluminum extrusions.
- Double-strength glass (DSB) is standard glazing material.
- Acrylic (Plex) and polycarbonate (Lexan) glazing available.
- Panels have heavy-duty magnet which adheres to steel tape.
- Lift out easily for cleaning.
- Custom colors, glazing, muntins and screens available.

MOUNT TO DEEP GUIDE CHANNEL

Plaster, drywall,
wood or metal jambs

MOUNT TO STEEL TAPE

Wood D/H

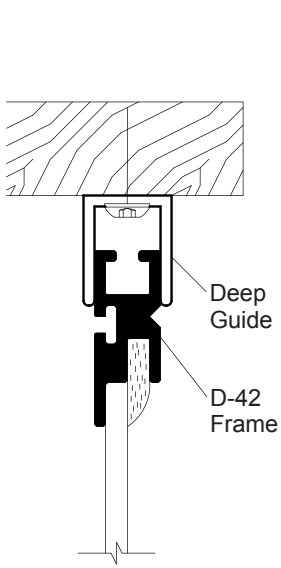

HEAD
Typical Condition

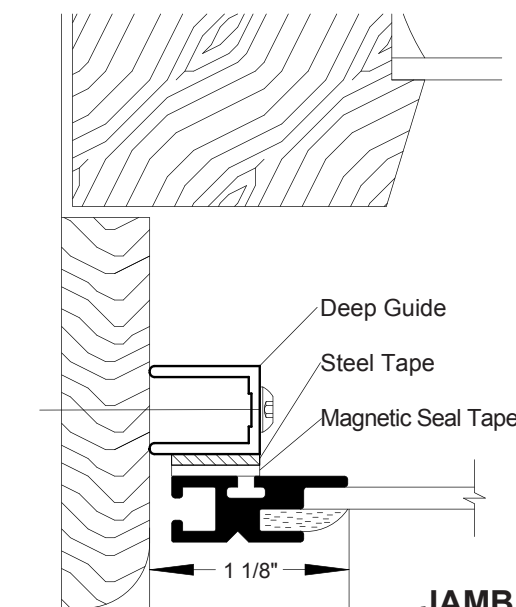

JAMB
Mounted on Deep Guide Stop within Wood Double Hung

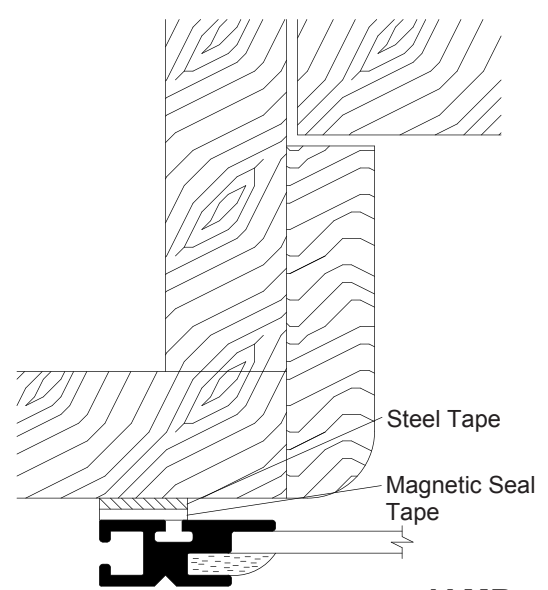

JAMB
Overlap Mount on Wood Double Hung

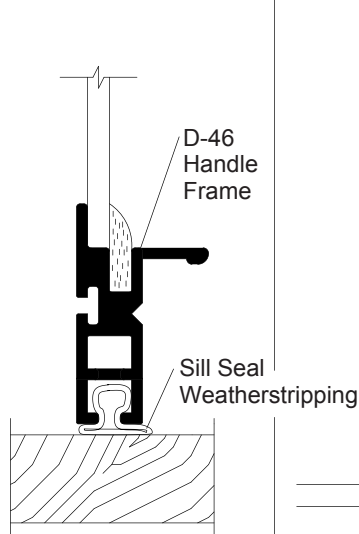

SILL
Typical Condition

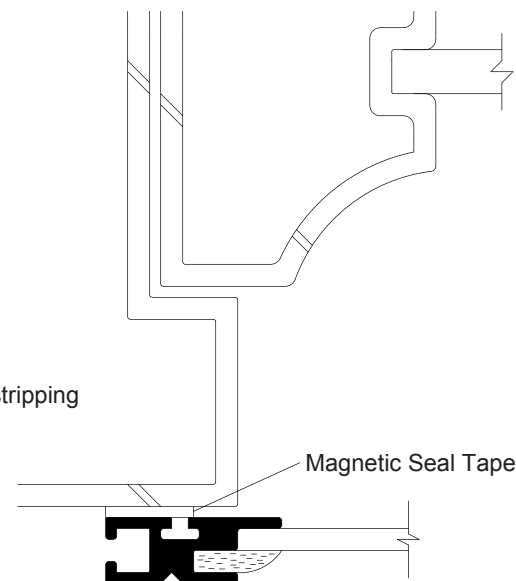

JAMB
Mounted on Steel Double Hung

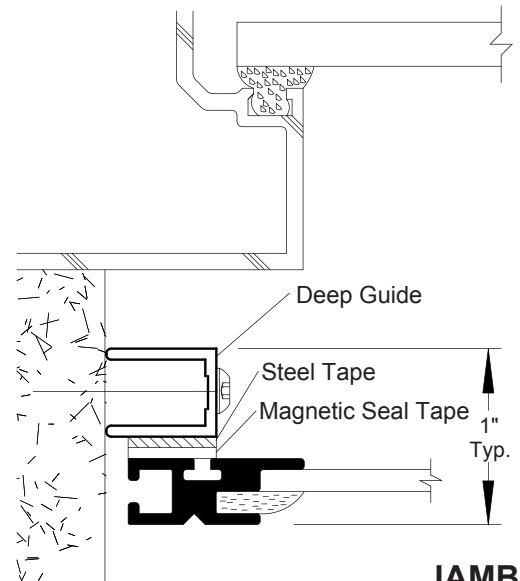

JAMB
Mounted to Deep Guide Stop behind Existing Aluminum Framing

HISTORIC ONE LITE "HOL"

Approved for exterior installation on historic renovation projects certified by the Department of the Interior (National Park Service)

The Historic One Lite (HOL) has been designed specifically for double-hung windows on historic commercial, industrial and residential buildings.

- Custom colors and shapes.
- Custom engineered.
- Trim lines — *practically invisible*.
- Unit projects only $\frac{3}{8}$ ".
- Panels remove to interior.
- No hardware on exterior.
- Interchangeable screen and glass.
- Frames and corners are heavy extrusions.
- Special glazing available.
- Glazing muntin available.
- Top sash of prime double-hung **must** be operable.

STANDARD DESIGNS

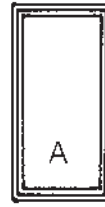

Removable Panel.
Screen Available.



Top Fixed.
Bottom Removable.
Screen Available.

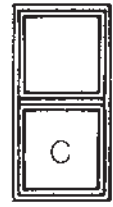

Top & Bottom
Removable.
Screens Available.

SPECIAL DESIGNS:

Special shapes such as circle-top, eyebrow, gothic, circular, trapezoid, etc. are available. Multiple units can be designed to suit virtually any sized opening.

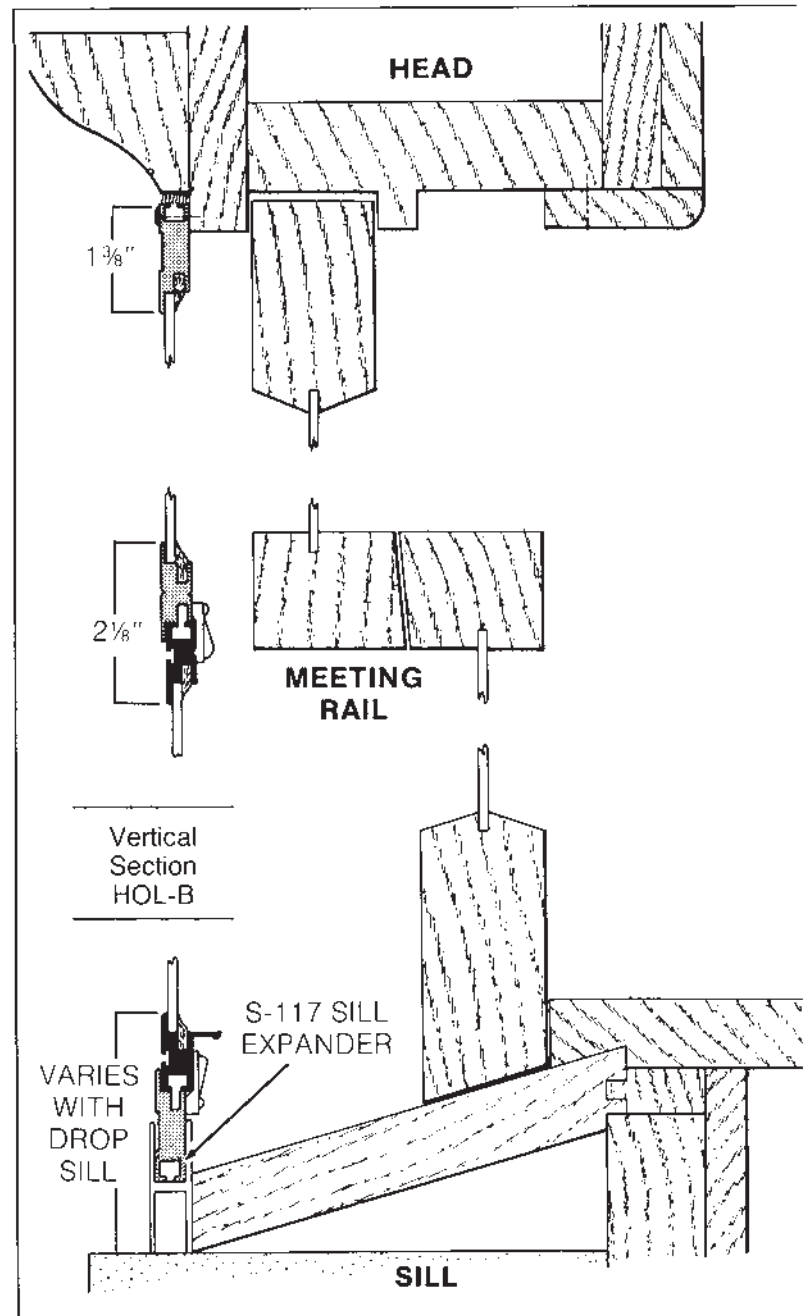
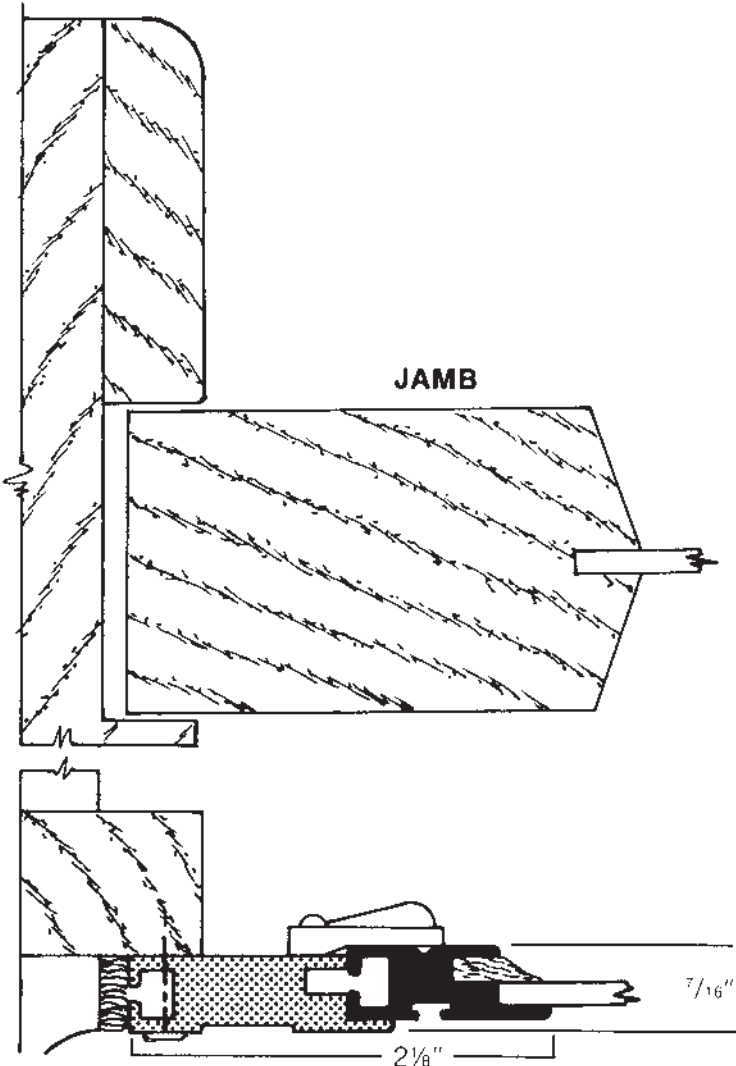

ALLIED ONE LITE "AOL"

STANDARD DESIGNS

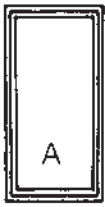

Removable Panel.
Screen Available.



Top Fixed,
Bottom Removable.
Screen Available.



Top & Bottom
Removable.
Screens Available.

SPECIAL DESIGNS: Special shapes such as circle-top, eyebrow, gothic, circular, trapezoid, etc. are available.
Multiple units can be designed to suit virtually any sized opening.

Approved for exterior installation on historic renovation projects certified by the Department of the Interior (National Park Service)

The Allied One Lite (AOL) has been designed for double-hung, fixed, projected, and hopper windows for commercial, industrial, and residential buildings.

- Can be mounted on exterior or interior.
- Custom colors and shapes.
- Custom engineered.
- Trim lines — *practically invisible*.
- Unit projects only $\frac{3}{8}$ ".
- Interchangeable screen and glass.
- Frames and corners are heavy extrusions.
- Special glazing available.
- Glazing muntin available.

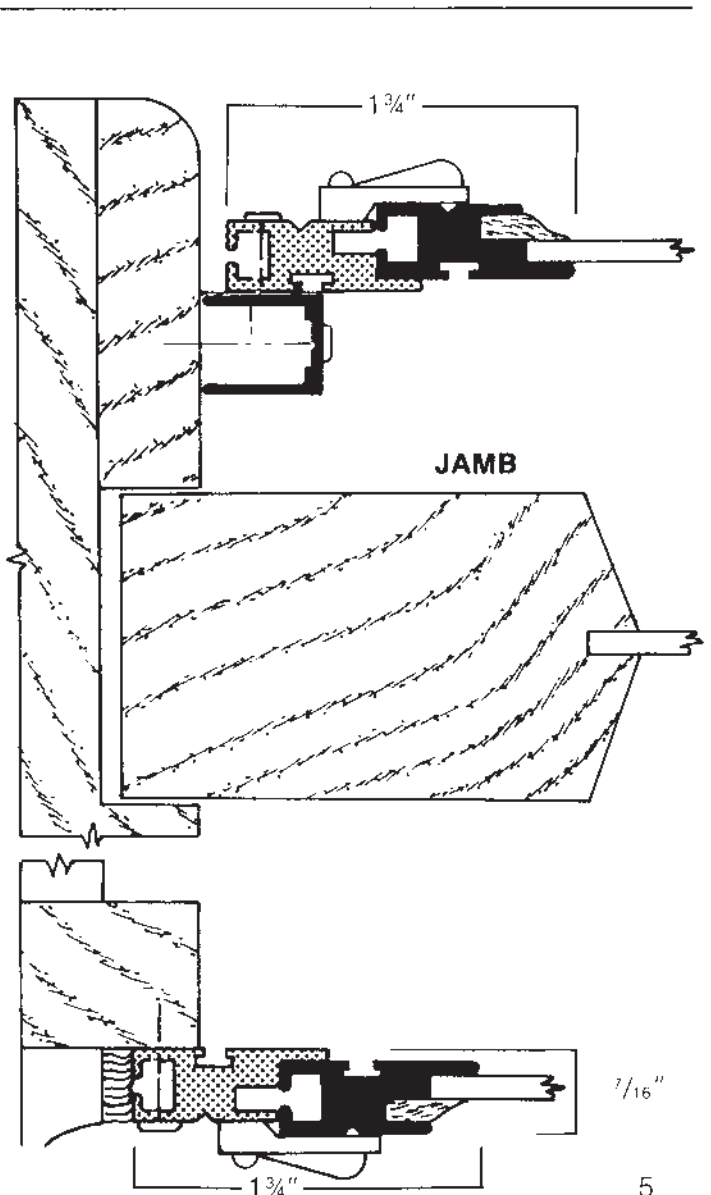
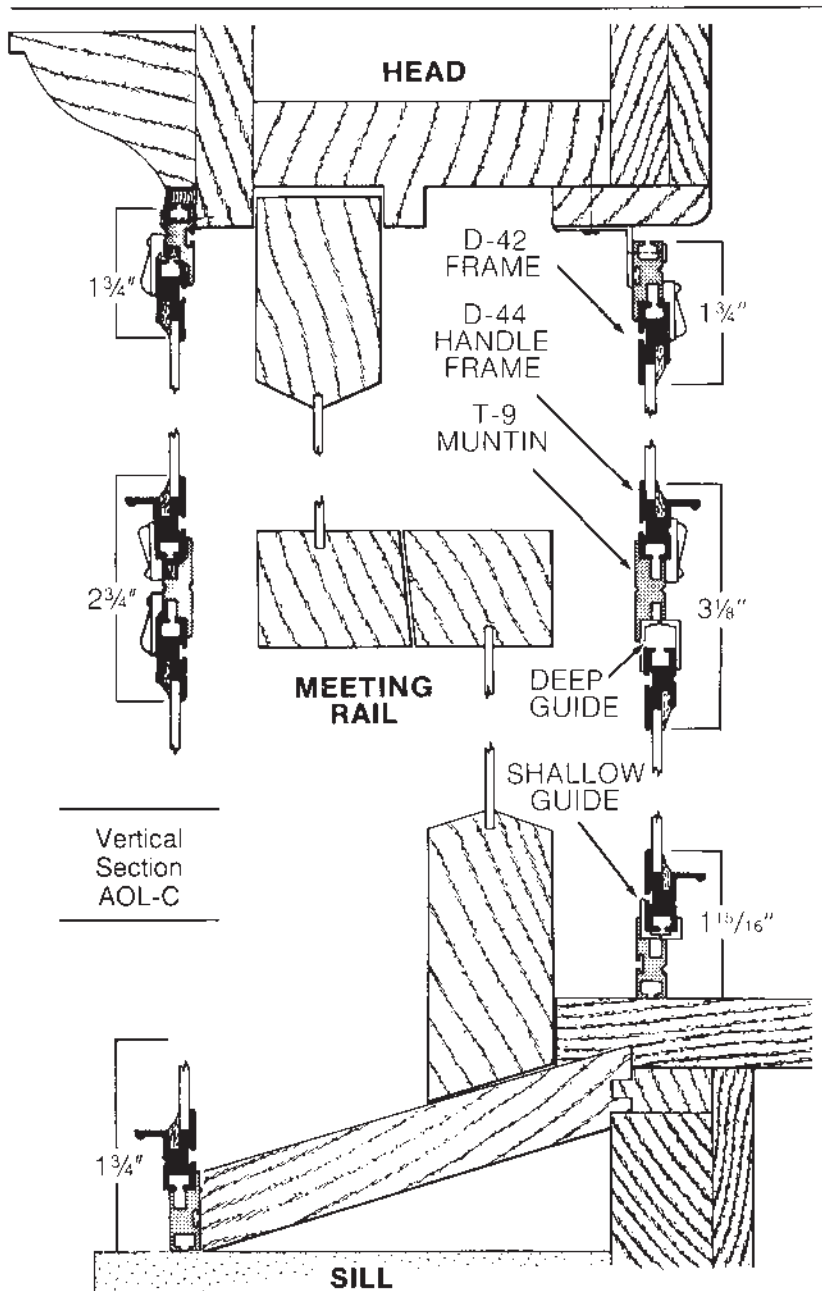

SLIDE-A-WAY "SAW"

STANDARD DESIGNS

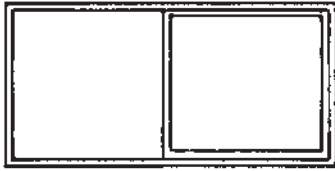

2-Panel SAW

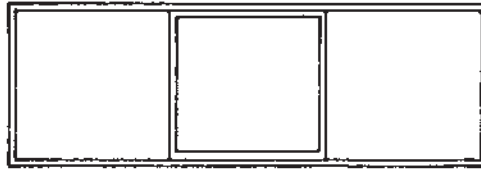

3-Panel SAW
(Additional panels available)

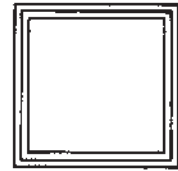

Lift-out SOL

Slide-A-Way (SAW) Interior Sliding Panels

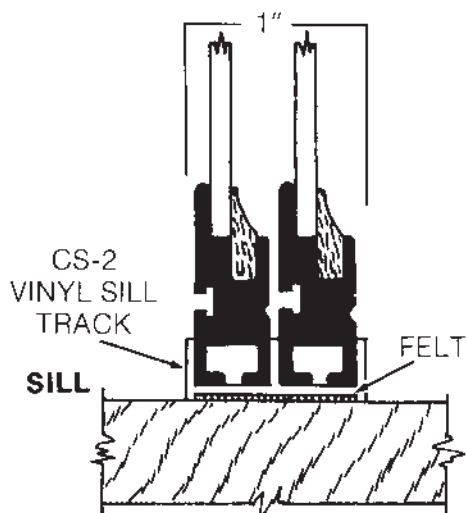
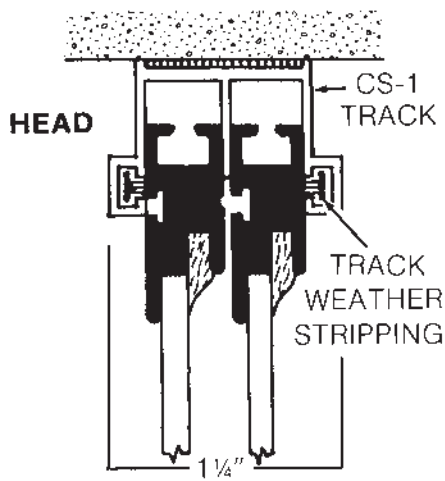

The Slide-A-Way (SAW) storm window has been designed specifically for interior application in commercial, industrial and residential buildings.

- Ideal for casement, sliding, fixed, projected hopper, awning or pivoting windows as well as large or multiple unit openings.
- Frames, tracks and corners are heavy extrusions.
- Trim lines — *virtually invisible*.
- Panels lift out for easy cleaning.
- Sliding panels for ventilation.
- Vinyl sill track (reinforcement optional).
- Fully weather-stripped.
- Custom engineered.
- Unlimited horizontal width.
- Can be stacked in opening.
- Other features available:
 - Custom colors
 - Heavy extruded screens
 - Special glazing
 - Glazing muntins
 - Swivel locks

Slide-A-Way One Lite (SOL) Interior Lift-out Panel

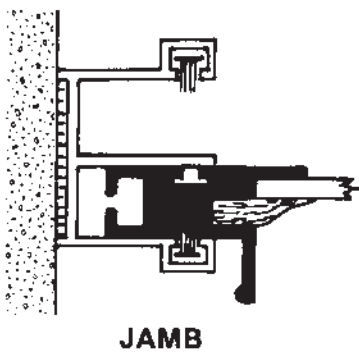
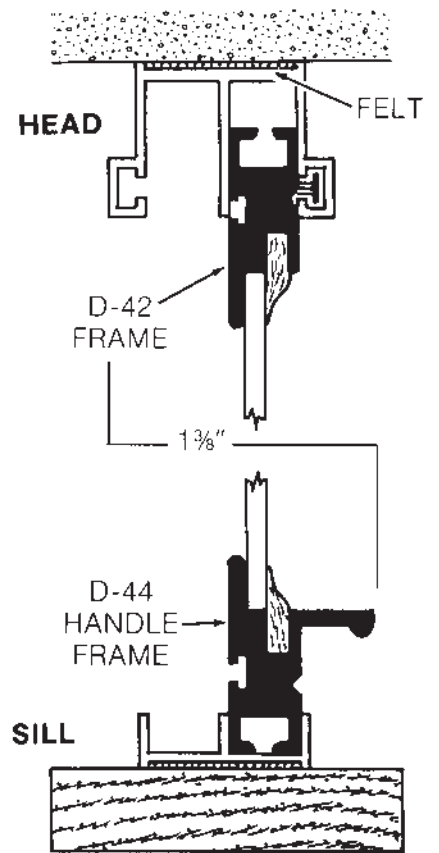

JAMB

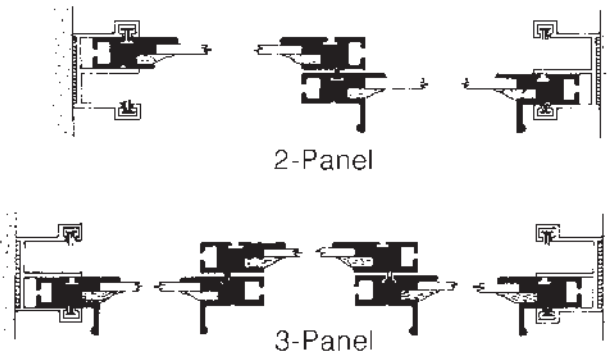

2-Panel

3-Panel

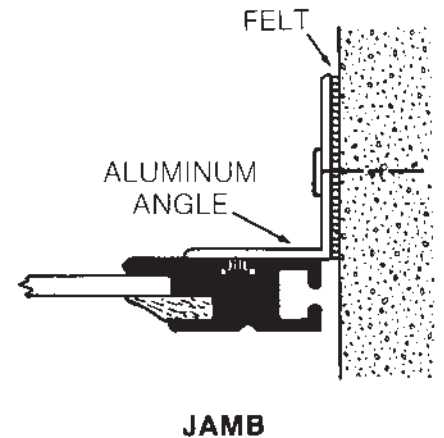

JAMB

CUSTOM SCREENS

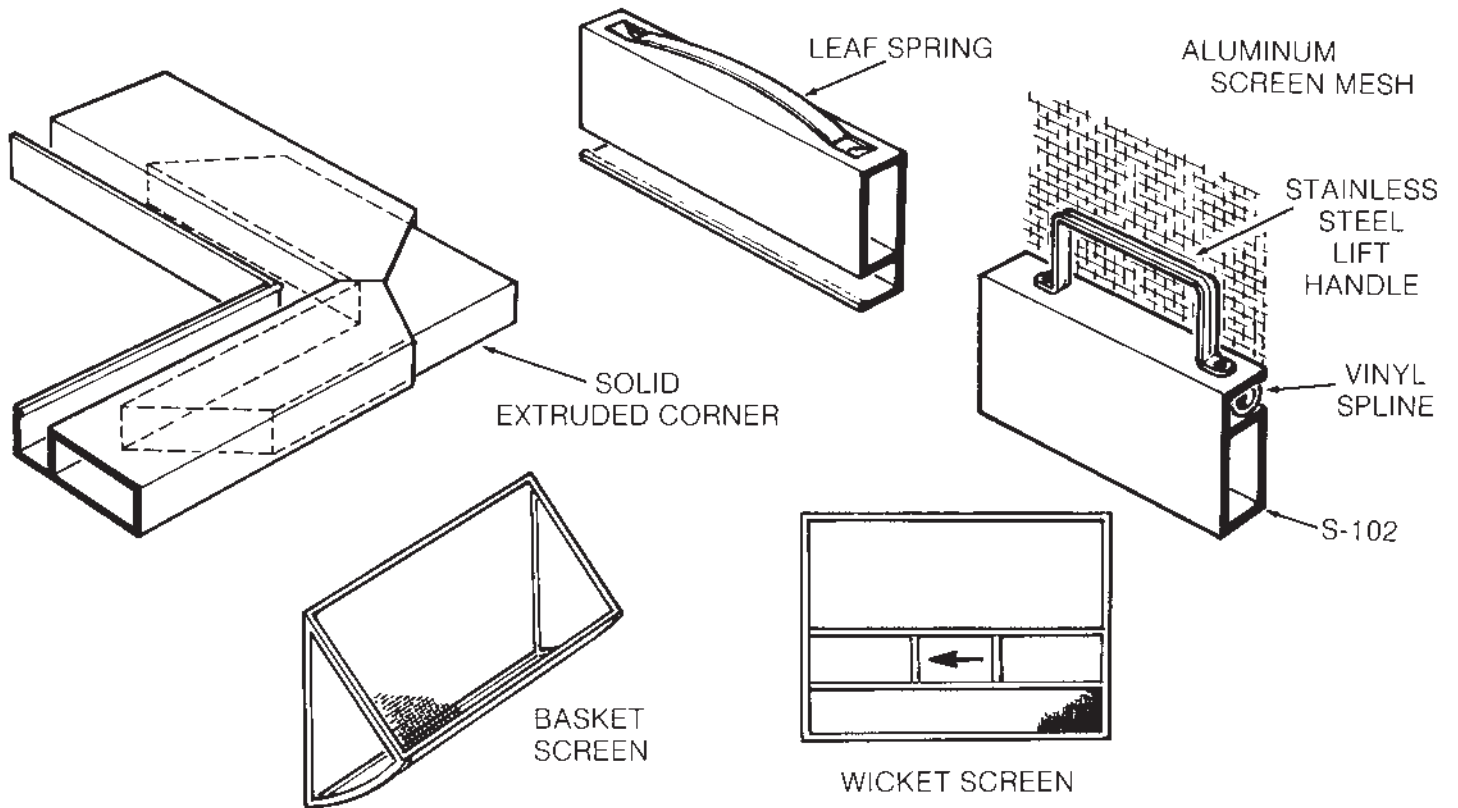

EXTRUSIONS

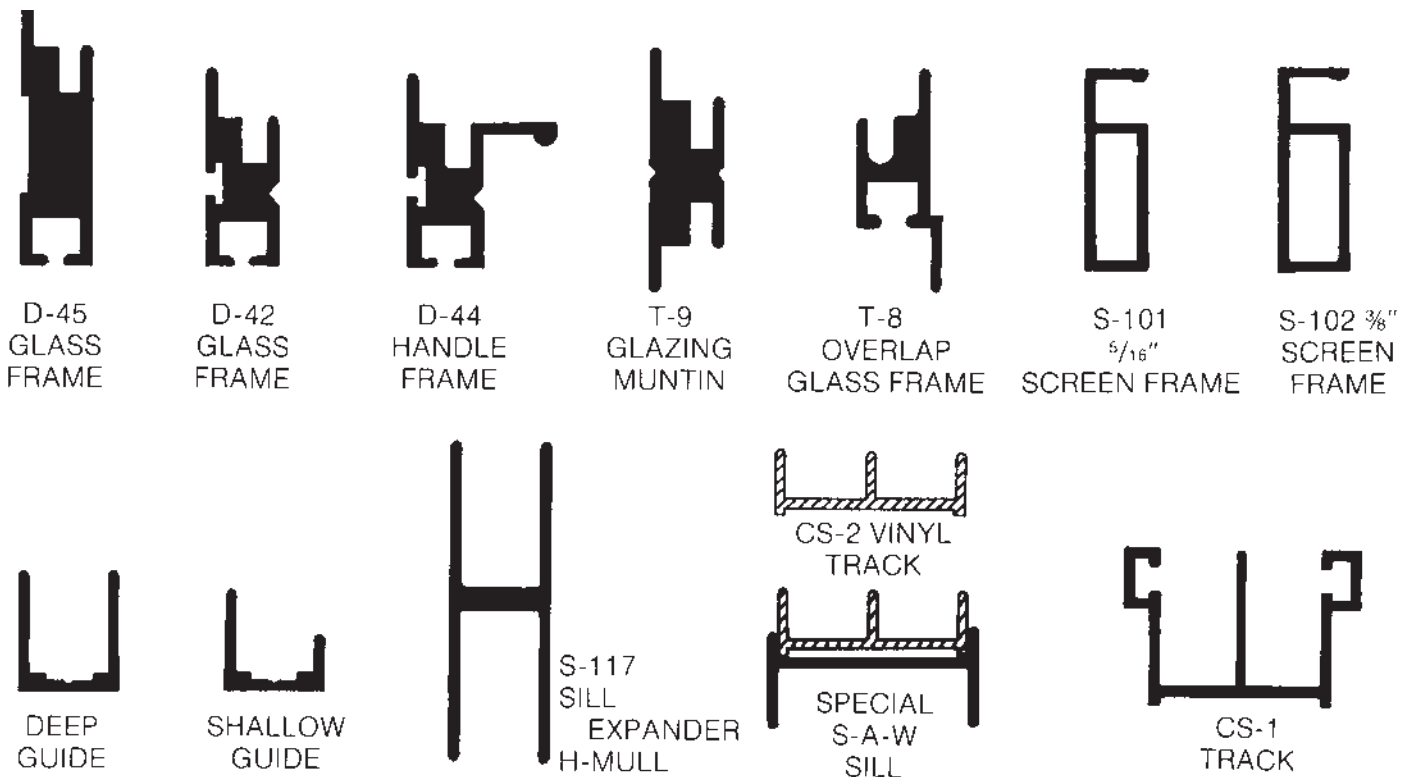

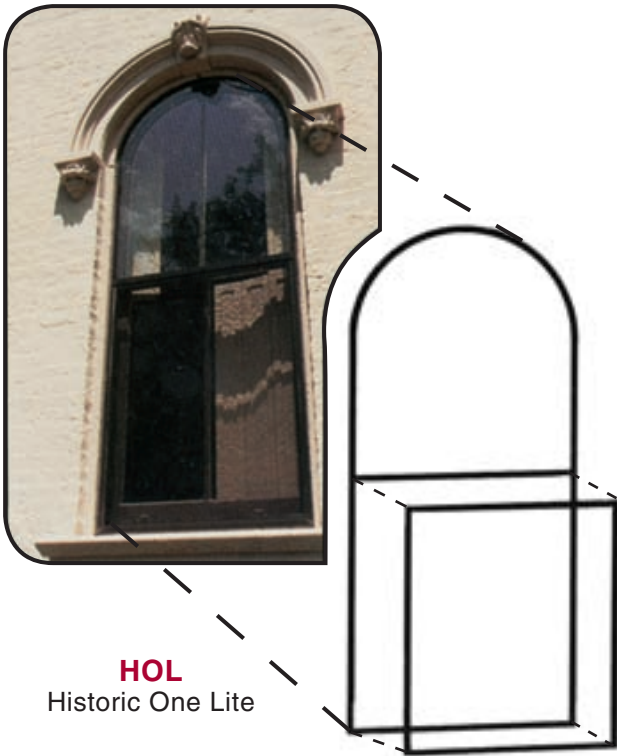

HOL
Historic One Lite

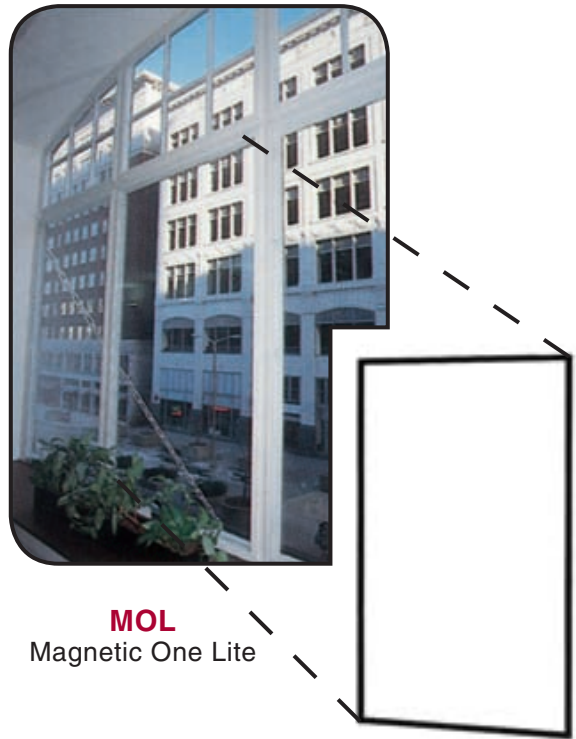

MOL
Magnetic One Lite

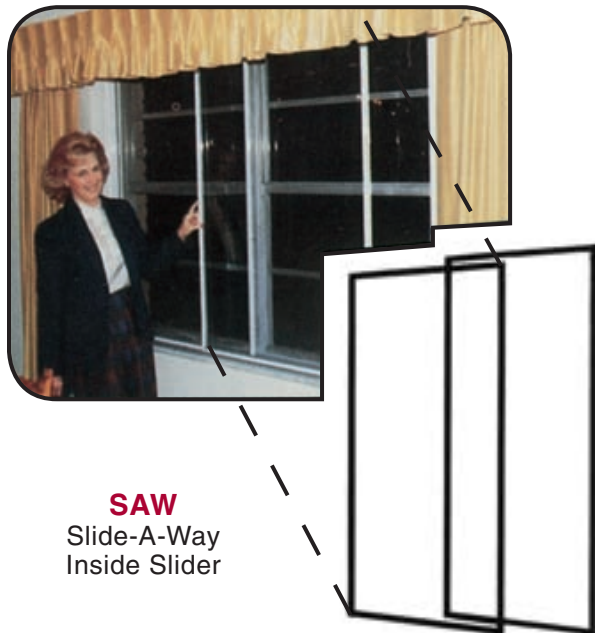

SAW
Slide-A-Way
Inside Slider

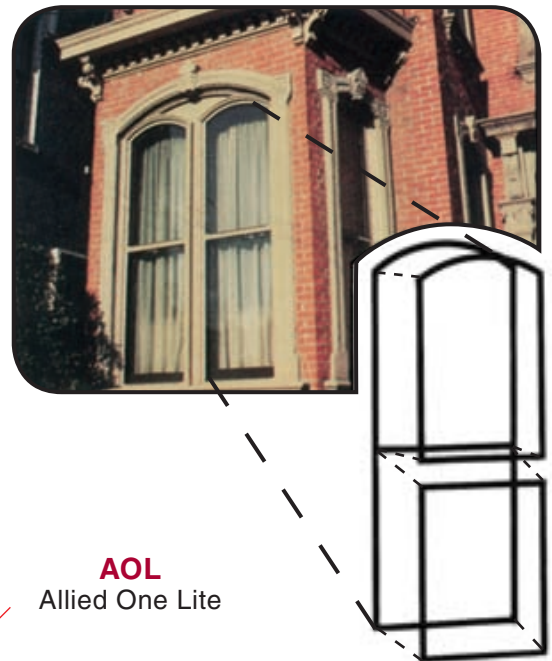

AOL
Allied One Lite



Custom Invisible Storm Windows®

(800) 445-5411

www.alliedwindow.com
www.invisiblestorms.com

11111 Canal Road • Cincinnati, Ohio 45241

STANDARD COLORS

