



# PRODUCT OVERVIEW

---



We are innovators. We are problem solvers. We are solution providers.  
We provide storage solutions every day, and we have done so for over forty years.



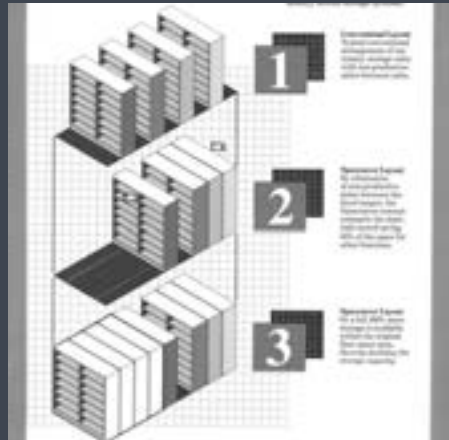

Spacesaver was founded in 1972 by Theodore W. Batterman in the small town of Fort Atkinson, Wisconsin. Ted's mission was to help organizations maximize space, save energy, and increase productivity, and he realized that high-density mobile storage could accomplish all three goals at once. Working out of a barn with only seven employees, he spearheaded the development of high-density mobile storage and shelving for the United States.

Spacesaver's client base has expanded dramatically since those early days, and today we've completed more than 300,000 installations in the U.S. and around the world. Our clients include a wide variety of organizations, from manufacturers to military bases to museums. In 1998 Spacesaver became part of KI, an employee-owned global company headquartered in Green Bay, Wisconsin, that was founded in 1941.

Our team of in-house engineers, project managers, and skilled manufacturers work with our extensive network of authorized distributors to provide our clients with well-designed, reliable, and aesthetically pleasing storage solutions. We look forward to working with you.

**SPACESAVER. STORAGE SOLVED.**



---

## **WE ARE PROBLEM SOLVERS.**

Spacesaver is committed to creating storage systems that save space, increase productivity, and decrease energy consumption. Our founder spearheaded the development of compact mobile storage in the United States, and our products are still engineered and manufactured in Wisconsin, USA.

## **WE ARE INNOVATORS.**

We don't simply sell products to our clients—we work with them to invent solutions. We hold nearly 200 patents and have collaborated with the U.S. Marine Corps, public safety departments, and others to create new products that have gone on to become standards in their respective industries.

## **WE ARE SOLUTION PROVIDERS.**

We strive to understand the complexities of our clients' space challenges and create complete solutions that integrate optimal workflow, safety, and security within each facility's unique structure. Our network of local distributors provides expertise from the earliest project design phases through product installation and maintenance, and we're committed to the highest standards of customer service.

**STORAGE SOLVED.**

---

# ON THE MOVE.

Compact storage systems free up space for increased productivity, improved organization, and enhanced appearance. Reclaim wasted space—and reimagine the possibilities—by consolidating and compacting stored items in mobile storage systems.







Glacier Fish Company | Seattle, WA  
Mechanical-Assist Mobile Storage System  
4-Post Shelving



► **SHELVES THAT SOAR**

Designed as a LEED® Silver building, the Zhang Legacy Collections Center uses 32' high-bay shelving units to consolidate collections that had previously been stored in various areas around the Western Michigan University campus. High-bay shelving provides convenient access for patrons while reducing operational costs, maintaining environmental controls, and freeing up space for other uses.



Western Michigan University | Kalamazoo, MI  
XTend Mobile High-Bay  
High-Bay Shelving

▼ **16,000 LBS. ON THE MOVE**

Engineered with seismic protection in mind, the Naval Undersea Museum in Keyport, Washington, uses heavy-duty mobile shelving to store massive torpedo artifacts. Some of these artifacts weigh upwards of 6,000 lbs. each.



Naval Undersea Museum | Keyport, WA  
ActivRAC 16P Mobilized Storage  
Powered Control, Cantilever Racking



► **WALLS THAT MOVE**

Moving walls create the ultimate flexible workspace at the San Francisco-area GE Design Center. The walls are wired for electronic displays and can be moved to create large event spaces or smaller areas for meetings and other collaborative work.



GE Design Center | San Ramon, CA  
Manual Mobile Storage System



Canadian War Museum | Ottawa, ON  
Mobile Art Rack



► **SHELVES THAT BREATHE**

Perforated shelving and end panels at a state university's law library allow air to circulate not only along the aisles but also through the shelves and the books themselves, helping maintain optimal conditions for preservation.

▼ **SIDE BY SIDE**

Mobile lateral shelving provides convenient access to electronic media at the Salt Lake City Public Safety Building. The shelving units move on rails from side to side, allowing staff to store more materials in less space while still permitting quick retrieval.



Law Library at a State University  
Powered Mobile Storage System  
Perforated Metal End Panels  
Cantilever Shelving



Salt Lake City Public Safety Building | Salt Lake City, UT  
Mechanical-Assist Mobile Storage System  
Universal™ Weapons Rack (UWR®) Storage System



U.S. Marine Corps Base  
Universal Weapons Rack (UWR®)  
Powered Mobile Storage System



Westwood | University of Notre Dame | Notre Dame, IN  
Mechanical-Assist Mobile Storage System  
4-Post Shelving with Drawers



► **NEW TECHNOLOGY**

Intuitive touch screen technology at Salve Regina University library allows students to easily open aisles and access the reference materials they need.



Salve Regina University | Newport, RI  
Powered Mobile Storage System with Touch Technology Control  
Cantilever Shelving

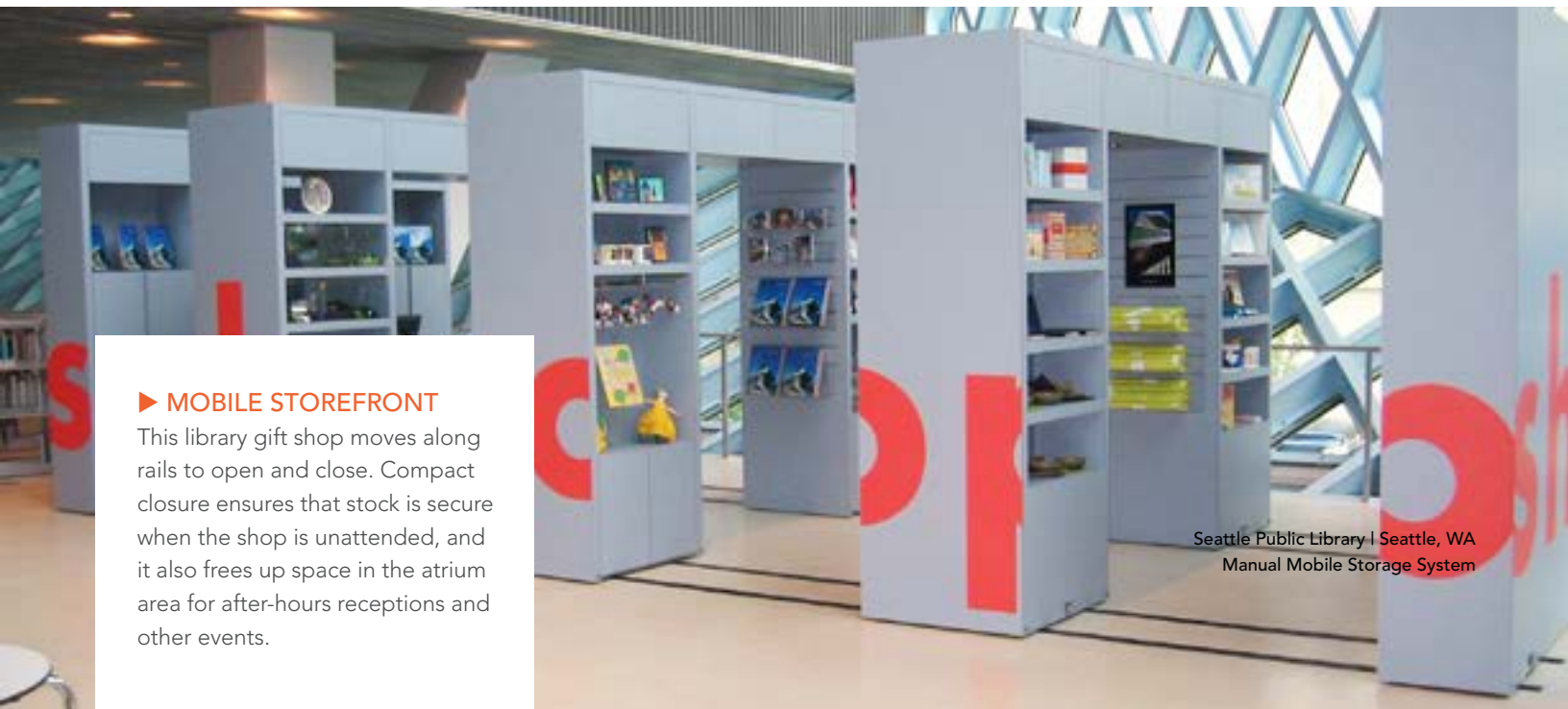

► **MOBILE STOREFRONT**

This library gift shop moves along rails to open and close. Compact closure ensures that stock is secure when the shop is unattended, and it also frees up space in the atrium area for after-hours receptions and other events.

Seattle Public Library | Seattle, WA  
Manual Mobile Storage System



## ▶ WHAT IS HIGH-DENSITY MOBILE SHELVING?

High-density mobile shelving concept allows our clients to store the same volume of items in a fraction of the space, allowing more room for storage or other uses.

In traditional shelving systems, a stationary shelving unit is followed by an aisle, followed by another unit, another aisle, and so on. High-density mobile shelving takes existing stationary shelves and places them on mobile carriages, eliminating wasted space and allowing aisles to be opened at the point of need.

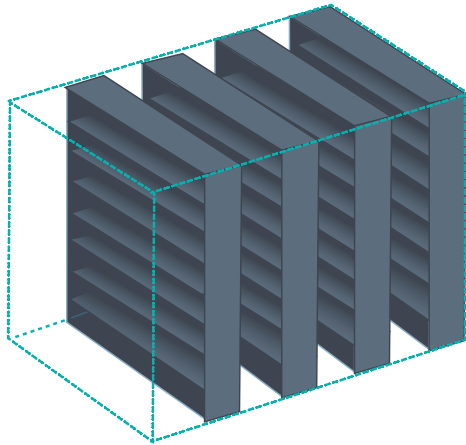

### TRADITIONAL SHELVING

#### **WASTES SPACE.**

With traditional static shelving, a large percentage of floor space is **wasted in aisles.**

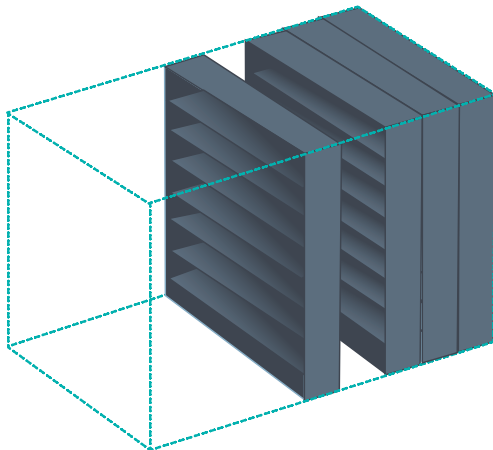

### MOBILE SHELVING

#### **INCREASES SPACE.**

Mobile shelving delivers the same capacity as static shelving in **less floor space.**

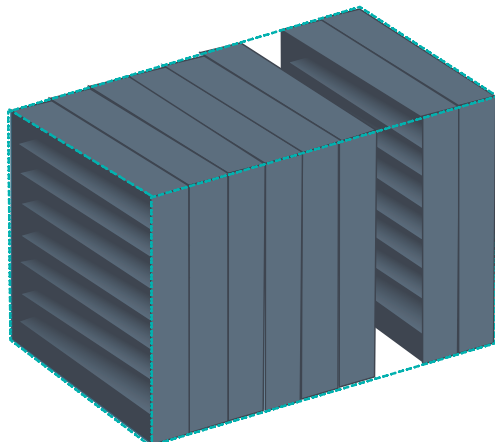

### MOBILE SHELVING

#### **INCREASES CAPACITY.**

Mobile Shelving allows you to **increase the storage capacity** of your existing floor space.

## ▶ MOBILE STORAGE



### STANDARD

---

Our most popular high-density mobile system is available in all modes of operation (manual, mechanical-assist, and electronic control). Welded steel carriage construction and safety features ensure safe, reliable operation.



### LOW-PROFILE

---

The Wheelhouse® modular mobile storage system creates a cost-effective, low-profile system for compact storage. This system can be relocated, making it perfect for businesses that are anticipating expansions and moves.



### HEAVY-DUTY

---

ActivRAC® mobilized storage system stores large and heavy items without facility expansion or renovation. Depending on the model, these heavy-duty systems can hold up to 7,000 to 30,000 pounds per carriage.



### MOBILE HIGH-BAY

---

XTend® mobile high-bay storage systems store materials from floor to ceiling and are typically used in warehouses. These systems can be several stories tall, requiring the use of a lift to access stored items.



### ART RACKS

---

Art racks on rails allow two-dimensional artwork to be stored safely and compactly. Available in a variety of options, our art racks offer smooth, sturdy operation and can fit in virtually any space.



### MOBILE LATERALS

---

Mobile lateral systems maximize storage capacity by placing one or two rows of sliding shelves in front of stationary shelving. The front shelves move from side to side, allowing more items to be stored in the same space.



# THE PERFECT PLATFORM

Selecting shelving is about more than choosing sizes and colors—it's about finding the perfect home for important items. Our shelving holds some of the world's most interesting objects, from rare books to surgical supplies to kegs of craft beer. Our shelving is manufactured in the USA and contains heavy-duty recycled steel, so our clients' storage solutions are always sturdy and sustainable.







Dartmouth University | Hanover, NH  
Cantilever Shelving System





California Academy of Sciences | San Francisco, CA  
4-Post Shelving with Bin Fronts  
Full-Height Flush Handle, Solid Panel Doors

### ▲ PROTECTING SPECIMENS

Bin fronts, or "earthquake bars," finish the front edges of the open upper shelves in these 4-post shelving units to prevent spillage or breakage in the event of an earthquake. The shelves are perforated to allow liquid from accidental spills to flow through the shelving and onto the floor, where the liquid can be drained out of the room.

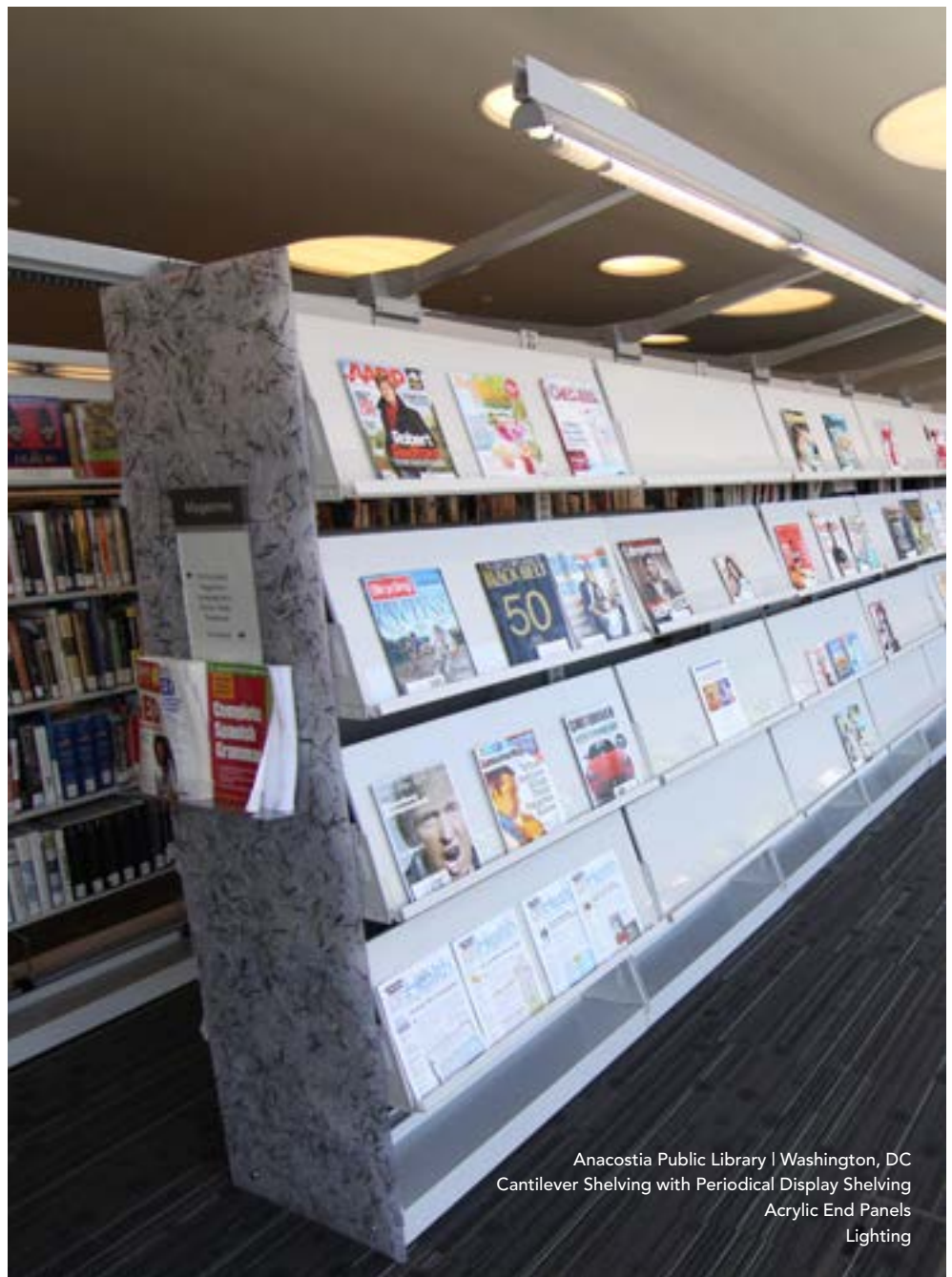

Anacostia Public Library | Washington, DC  
Cantilever Shelving with Periodical Display Shelving  
Acrylic End Panels  
Lighting

► **STREAMLINING WORKFLOW**

Modular bin shelving systems help improve efficiency and streamline workflow. These systems are popular in supply rooms, pharmacies, IT departments, and other settings that require compact storage for small items.



Peterborough Regional Health Centre | Peterborough, ON  
FrameWRX® Storage System  
EZ Rail with Bins



California Academy of Sciences | San Francisco, CA  
Wide-span Shelving  
Wire Racking



Salt Lake City Public Safety Building | Salt Lake City, UT  
WeaponWRX® Cart



## ► STERILE STORAGE

In an effort to provide patients with state-of-the-art procedure rooms that accommodate new, high-tech medical equipment, staff at this hospital removed supply storage from the procedure rooms and relocated the items to a central supply room. Sterile wire shelving now houses surgical kits and instruments in a convenient location.



Sterile Supply Storage  
7P ActivRAC® Mobile Storage System  
4-Post Shelving with Stainless Steel Wire Shelving



Cambridge Community Library | Cambridge, WI  
A-Frame Cantilever Cart  
Wood End Panels



University of Wisconsin-Madison Libraries | Madison, WI  
XTend® Mobile High-Bay Storage System  
High-Bay Shelving



► **CONFIGURABILITY**

Originally designed to secure weapons, WeaponWRX steel pegboard is now used in a wide variety of applications. Whether it's storing evidence in a forensics facility, crutches in a sports medicine clinic, or lawn care implements at a municipal parks department, WeaponWRX backing provides sturdy, fully configurable support.



Illinois Metro East Forensics Science Lab | Bellevue, IL  
WeaponWRX® Storage System  
Powered Eclipse® High-Density Mobile Storage



Washington State University | Pullman, WA  
Mechanical-Assist Compact Mobile Storage System  
Dividers and Bin Fronts for Player Specific Cubbies



## ► SHELVING



### 4-POST & CASE-TYPE SHELVING

---

Designed to adapt to stationary and mobile storage applications, 4-post and case-type shelving offers versatile and cost-effective storage solutions. This shelving becomes even more versatile and secure when fitted with doors that latch and/or lock.



### CANTILEVER

---

Cantilever shelving and display systems are ideal for academic, corporate, public, and legal libraries, as well as museums and general office spaces. Our cantilever shelving is designed to adapt to both stationary and mobile storage applications.



### WIDE-SPAN

---

RaptorRAC™ widespan shelving provides a wide platform for storing large and bulky items. Whether it's storing parachutes on a military base, stock in a warehouse, or evidence in a police station, RaptorRAC offers sturdy support and convenient access.



### MODULAR SHELVING

---

Highly customizable and easily relocated, the FrameWRX® storage system adapts to changing needs. Options such as WRX Wheels® transport system, FrameWRX® HD (high-density) storage system, and EZ Rail® element offer unlimited storage possibilities.



### MODULAR WEAPON SHELVING

---

WeaponWRX® storage system provides secure weapons storage, even during transport. Rugged, modular steel frames can be configured to fit into any space and outfitted with a combination of specialized accessories.



### HIGH-BAY

---

Static high-bay shelving is built for stable storage of book trays, archival boxes, and other materials. These systems can reach more than four stories tall, so a lift is required to access stored items on upper levels.



## WIRE SHELVING

The open design of wire shelving minimizes dust accumulation and permits better air circulation, greater visibility of stored items, and maximum light penetration.

### ▼ A VIEW FROM ABOVE

Translucent acrylic top and end panels eliminate visual barriers, adding to the open and expansive feeling at the Seattle Central Library.



Seattle Central Library | Seattle, WA  
Cantilever Shelving  
Periodical Display  
Acrylic Top & End Panels  
Custom Lighting



# A PLACE FOR EVERYTHING.

Many of Spacesaver's unique and innovative storage solutions are the direct result of a challenge faced by a client—challenges such as needing more space, requiring increased security, or wanting improved efficiency. Our engineering team routinely collaborates with a wide variety of clients to create storage solutions that meet and exceed expectations.







► **GEAR ACCOUNTABILITY**

Our heavy-duty steel gear lockers keep equipment accessible yet secure, and we offer a variety of sizes and configurations to meet any requirement. The gear lockers at Fort Carson were the key to winning a Supply Excellence Award for outstanding organization, supply accountability, and security.



Fort Carson | Fort Carson, CO  
FreeStyle® Gear Bag Lockers  
Diamond Perforated Doors  
Hasp Lock



SHARKCAGE® by Spacesaver  
Tactical Locker on CROP UHD

► **READY AND SECURE**

Camp Lejeune, a 246-acre military training facility, needed to organize weapons and gear in the most efficient manner possible. Universal Weapons Racks offered soldiers convenience and configurability, with a variety of accessories allowing optics to be securely stored on weapons during transport.



Marine Corps Base Camp Lejeune | Jacksonville, NC  
Universal Weapons Rack (UWR®)  
Storing M2s with Barrels



Central Marin Police Department | Larkspur, CA  
Pass-Thru Evidence Locker  
Small Refrigerated Evidence Locker





Central Marin Police Department | Larkspur, CA  
Sally Port Gun Locker



Margaret and Angus Wurtele Study Center  
Yale University | New Haven, CT  
Museum Cabinets with Glass Doors

### ► BOOSTING MORALE

The team tasked with designing the new Skokie Police Department headquarters had one overarching goal: to create a more positive work environment for police officers. With that goal in mind, the design team chose to outfit the officers' locker rooms with configurable personal lockers that included a range of features, from durable benches to modular electrical components. The resulting locker rooms serve as an oasis of comfort and security before and after hectic shifts.

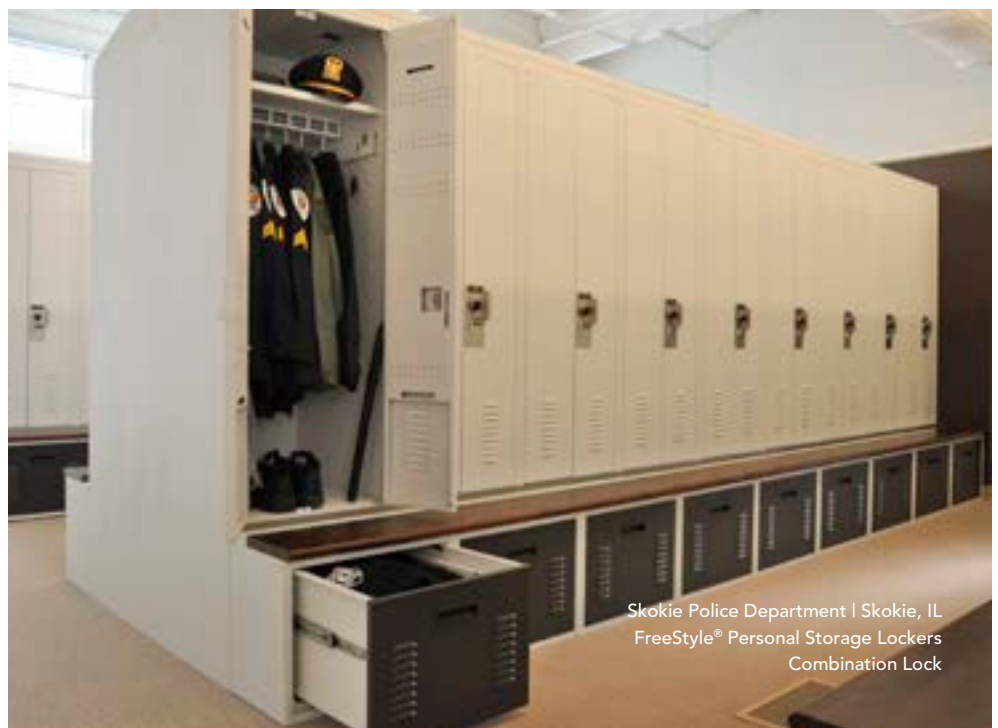

Skokie Police Department | Skokie, IL  
FreeStyle® Personal Storage Lockers  
Combination Lock



► CUSTOM LOCKERS

Our in-house engineering team can create solutions for virtually any need. These lockers were custom designed to provide convenient storage for the University of Wisconsin-Whitewater's wheelchair basketball teams.



University of Wisconsin-Whitewater | Whitewater, WI  
FreeStyle® Personal Storage Lockers



Fort Stewart | Fort Stewart, GA  
Universal™ Weapons Rack (UWR)  
Powered Eclipse® High-Density Mobile Shelving

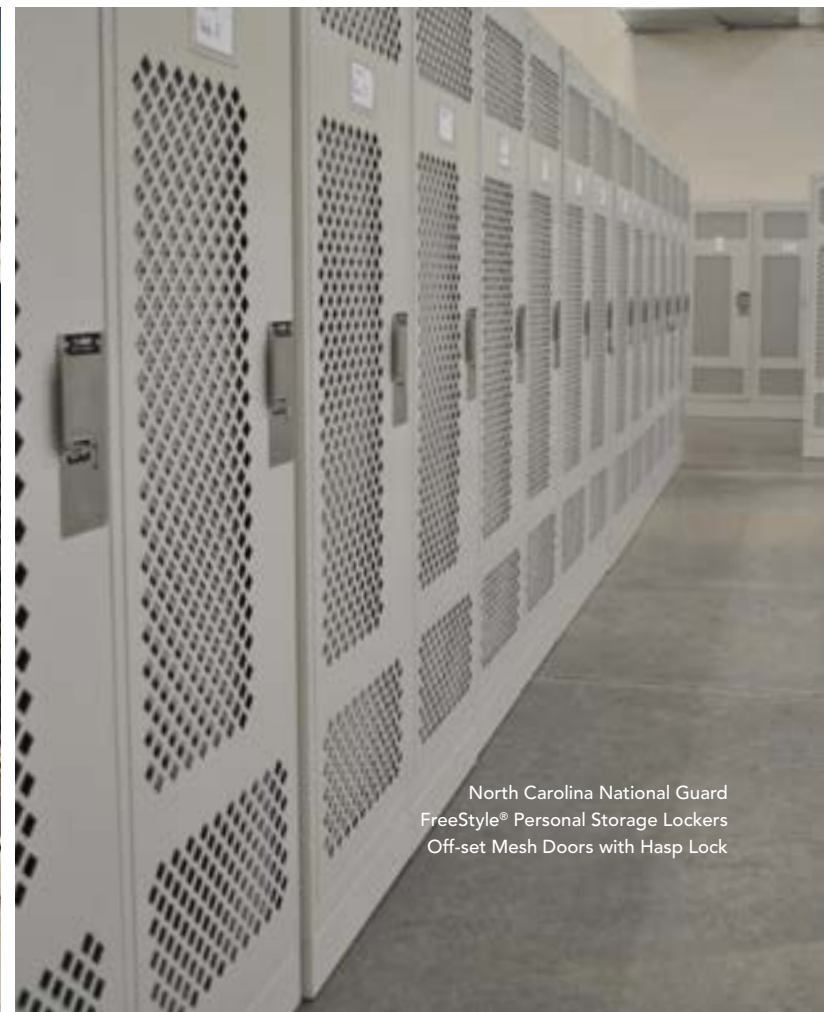

North Carolina National Guard  
FreeStyle® Personal Storage Lockers  
Off-set Mesh Doors with Hasp Lock



## ► STORAGE



### PERSONAL STORAGE LOCKER

---

FreeStyle® personal storage lockers allow personnel to easily store all their gear—including equipment, uniforms, and electronics—and reconfigure accessories as needed. Optional louvers and drying drawers facilitate proper ventilation.



### EVIDENCE LOCKER

---

With pass-thru and non-pass-thru options, our keyless evidence lockers offer a wide range of features and configurations to provide a secure chain of custody for short-term evidence storage.



### GUN LOCKERS

---

Available in floor- or wall-mounted options, secure gun lockers provide safe and secure temporary handgun storage for sally ports, interview rooms, and common areas.



### WEAPONS RACKS

---

Versatile and flexible, the Universal Weapons Rack ensures secure weapons storage and transport. When fitted with UWR® storage system accessories, weapons are further protected from vibration, shock, and abrasion, and most optics and accessories can remain assembled and zeroed to weapons while in storage.



### WELDED CABINETS

---

Our welded cabinets provide security, protection, and organization for a variety of storage applications. Built around 4-post uprights, these cabinets provide the same shelving configurability and compatibility with UWR® accessories as our open shelving units.



### MUSEUM CABINETS

---

Museum storage cabinets are tailored to meet specific storage requirements with optional locking glass doors, drawer systems and other custom features. Cabinets can be stationary or mounted on mobile carriages to make even more efficient use of available space.



---

## ACTIVESTOR

The ActiveStor® file management system offers classic lateral file cabinets, bookcases, large storage cabinets, and under-desk storage pedestals.



---

## UNIVERSAL CONTAINER

Designed with input from parariggers around the world, the Universal storage container is a durable and user-friendly product for optimally storing first responder products. Store the Universal storage container on Spacesaver's ActivRAC® mobilized storage system for the ultimate in convenience and storage density.



---

## READINESS LOCKER

The modular design of the Tactical Readiness Locker (TRL™ storage system) provides flexible gear storage for a variety of requirements. Lockers are available in a broad selection of sizes and configurations, and modular accessories complete the fully customizable interior.



---

## DEPLOYABLE STORAGE

SharkCage® by Spacesaver is a series of transport cages that optimally fit in most shipping containers. Which makes this solution ideal for contingency, deployment and container management. These cages have a heavy-duty collapsible design, access from both sides, self centering stacking, strapping points on each shelf and ammunition certification.



---

## WEAPONS STORAGE SYSTEM

The Universal Expeditionary™ Weapons Storage System (UWESS) is the first custom integrated container that is capable of storing and shipping modern small arms, crew serve weapons, associated collateral gear, and repair parts in a most secure fashion within a (Type 1) TriCON.



# CONSIDER YOUR OPTIONS.

Our accessories and options enhance any project. Our standard offerings include a wide range of sizes, colors, safety features, and other options, so be sure to contact your local authorized distributor to learn about all the possibilities. We also collaborate with architects and designers to engineer and manufacture custom solutions. For additional information about our products and services, please consult your local distributor or visit [www.spacesaver.com](http://www.spacesaver.com)







St. Louis Public Library | St. Louis, MO  
Cantilever Shelving  
Back-lit Glass End Panels





---

Spacesaver and its extensive network of authorized distributors is committed to providing excellent customer service to all our clients at all times, from project design and product installation to ongoing maintenance long after the sale. We pledge to treat our clients fairly and respectfully, to design and manufacture the highest quality storage systems on the market, and to complete projects on time and on budget.

STORAGE SOLVED.



---

# CONNECT WITH YOUR LOCAL DISTRIBUTOR

Spacesaver's extensive network of local distributors employs design consultants, sales specialists, and service technicians who are ready to help design, install, and maintain any project, no matter its size or scope. Our distributors often act as liaisons between our clients and their architects and interior designers, providing assistance regarding floor loading, architectural constraints, building codes, and a wide range of other concerns.

From complimentary space assessments, to project design and coordination, to product installation and ongoing service, our storage experts pride themselves on exemplary customer service. We have the expertise to successfully complete any project and we encourage you to contact us with your questions and ideas.

Call us at 800.492.3434 or visit us at [www.spacesaver.com](http://www.spacesaver.com).







Spacesaver Corporation  
1450 Janesville Avenue  
Fort Atkinson, WI 53538-2798  
1-800-492-3434  
[www.spacesaver.com](http://www.spacesaver.com)



KI  
1330 Bellevue Street  
P.O. Box 8100  
Green Bay, WI 54302-8100  
1-800-424-2432  
[www.ki.com](http://www.ki.com)

Spacesaver Corporation is a division of KI.  
KI is a registered trademark of Krueger International, Inc.  
Spacesaver is a registered trademark of Spacesaver Corporation.  
© 2016 KI and Spacesaver Corporation. All Rights Reserved. Litho in USA. ProductOverview\_Broch\_0316