

B72 BLUELIFT

The BLUELIFT Series

Meet our line of aerial lifts from the well-renowned Italian manufacturer Bluelift s.r.l., now exclusively distributed in the US, Canada and Mexico by ReachMaster Inc. Innovation, quality, superior design and above all safety are trademarks of Bluelift s.r.l.. With working heights from 39 to 72 feet, in and outdoor use and access through a single or double door. We now offer the BlueLifts with lithium batteries and motor combined. This combination is a first on the market for this size of compact lifts. The BlueLift series appeals to a broad range of applications: Rental industry (residential as well as commercial), window cleaners, building maintenance, tree care industry and HVAC operators to mention a few.

- Available in 5 models from 39ft - 72ft
- Now Available: Lithium battery and motor
- Pass through a single or double door opening
- Automatic outrigger setting
- Full workheight with 440 lbs in the basket
- Remote and wireless control
- 110V to the basket
- Set up on uneven surfaces
- FMS (Function Memory System)

Model	B72
Working height	72ft
Basket height	66ft
Max outreach	36ft (max outrigger)
Basket load	440lbs
Basket dims	4ft3 ³ / ₄ in x 2ft3 ¹ / ₂ in
Basket rotation	+/-80°
Turret rotation	360°
Height	6ft6in
Length (w/o basket)	14ft8 ¹ / ₂ in
Length (w/ basket)	17ft3in
Width (w/o basket)	3ft1in
Footprint	Variable
Weight (approx)	6,600lbs
Max pressure, tracks	6.7psi
Max pressure, footplate	71.1psi
Track size (per track)	58-3/4in x 9 ¹ / ₂ in
Foot pad size (per pad)	48 ¹ / ₂ sq in
110V drive motor	Standard
Honda gasoline engine	Standard
Hatz diesel engine	Option
Lithium battery	Option

We reserve the right to alterations

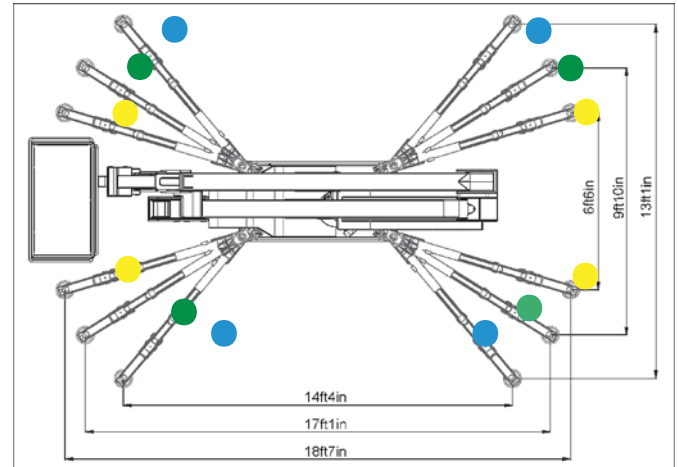
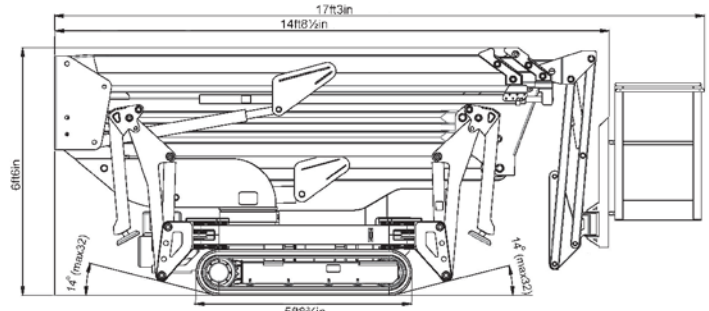
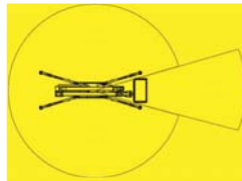
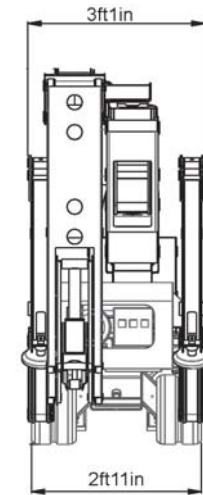
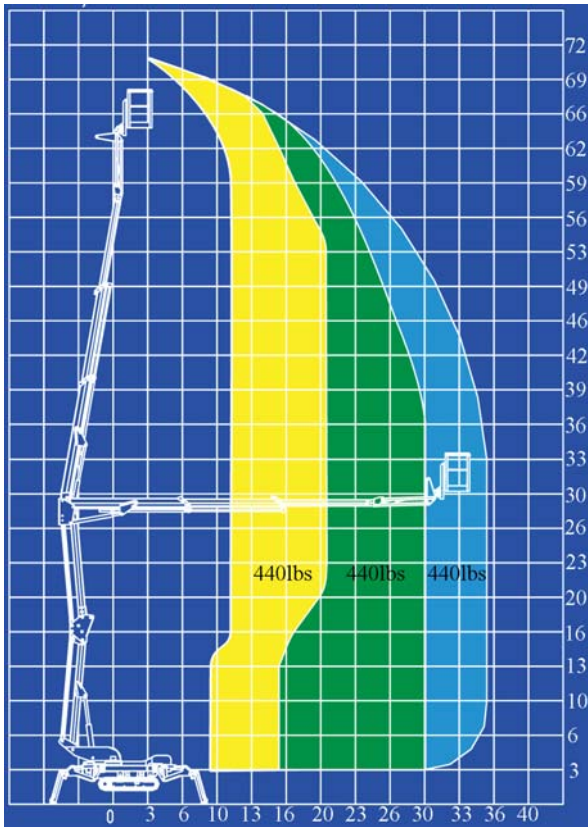

B72 BLUELIFT

Standard Equipment

- Automatic stability & outreach control
- Computer controlled (can-bus)
- Non marking tracks
- Self propelled
- 110V drive motor
- Honda iGX440 15HP engine
- 360° non cont. turret rotation
- Manual pump for emergency lowering
- Width of only 3ft11in
- 2 person basket
- Full work height with 440lbs in basket
- Full outreach with 440lbs in basket
- Air/water to the basket
- 110V to the basket
- Adjustable tracks
- 160° (+/-80°) basket rotation
- Wireless control
- FMS (Function Memory System)
- Automatic turret center stop

We reserve the right to alterations

Optional Equipment

- Hatz diesel engine
- Lithium Battery

Additional Specifications

- Boom angle 0°/ +75°
- Oil tank capacity 8gal
- Max windspeed 28mph
- Operating speed 0.9mph
- Travel speed 0.9mph
- Drive gradability 15%/28%
- Set-up gradability 10%/18%
- Outrigger set up (outside measurement)
 - 15ft2in * 13ft9in
 - 17ft9in * 10ft6in
 - 19ft3in * 7ft2in



ReachMaster, Inc.
1416 D Stonehollow Dr.
Kingwood, TX 77339
TF: 866-358-7088
Tel: 281-358-7088
Fax: 281-359-3500
www.reachmaster.com